

D1384 XY Bragg Angle Adjustment

The D1384 XY AO deflector is very sensitive to input beam (or Bragg) angle. This is illustrated in the plot below for two popular D1384 models designed for 355nm and 515nm. The X-Y modules are NOT pre-aligned at Isomet. Both X-axis and Y-axis AOD's will require Bragg angle adjustment once integrated into the system. Page 8 on provides example images.

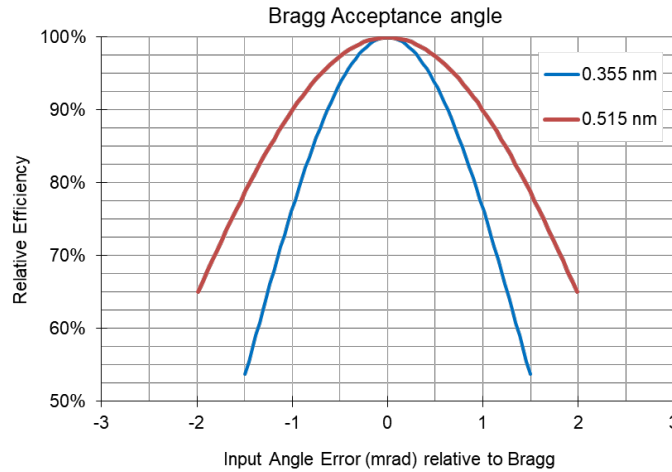

Determining the correct input Bragg angle is critical to achieving an efficient and uniform scan. The Bragg angle is optimized at the mid-scan drive frequency.

Method Overview

- Set the Bragg angle for the X-axis (Y-axis OFF).
- Set the Bragg angle for the Y-axis (X-axis, is correctly Bragg adjusted and ON).
- Optimize half-wave plate rotation. (Both axis, Bragg adjusted and ON at mid-scan frequency).

Unless stated, Isomet XY AO deflectors are designed with the laser input to the X-axis. In general an AO deflector can be operated in ("plus first") +1st order or ("minus first") -1st order. Either orientation can be selected. The sketch below shows typical 2D outputs including the desired XY diffracted scan pattern and the peripheral non(2D)-diffracted beams:

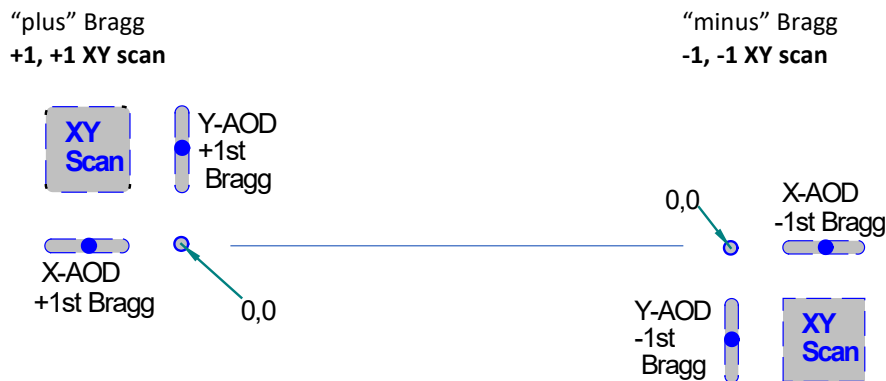

The 0,0 output is on-axis with the input beam. All laser power is at this beam position when the RF drive to both AOD's is OFF.

1. Configuration for +1, +1 XY scan

1.1 RF connections

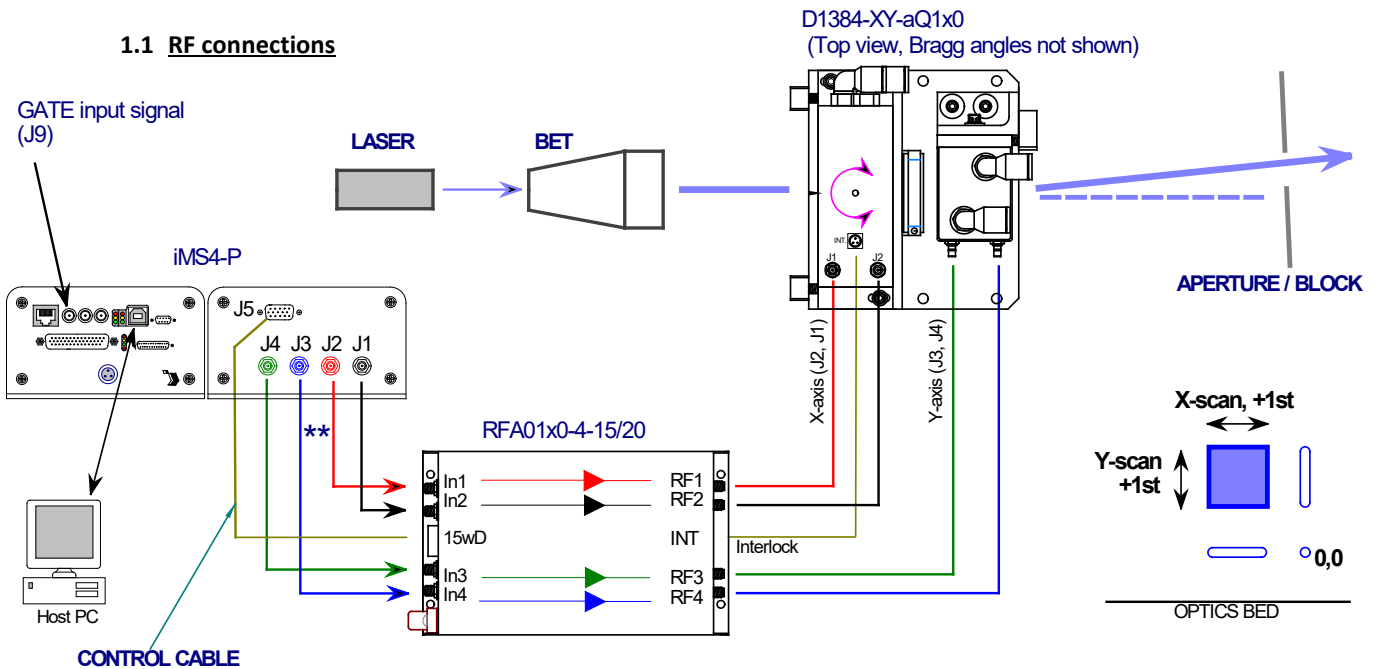

** Note the specific connection order between the four iMS4 outputs to the RFA01x0-4 amplifier inputs.

1.2 Beam Alignment

Angles and lateral adjustments exaggerated for clarity

As drawn here, the correct Bragg angle requires a counter-clockwise rotation of the AO deflectors from normal incidence of the input beam.

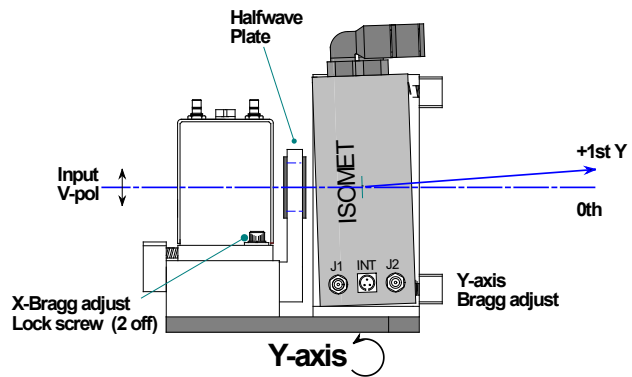

1 Align beam central in aperture, above Bragg Pivot point.

2 For the Y-axis, use slotted holes on the AOD mounts for lateral movement. Align X-axis 1st order output in centre of Y-axis active aperture.

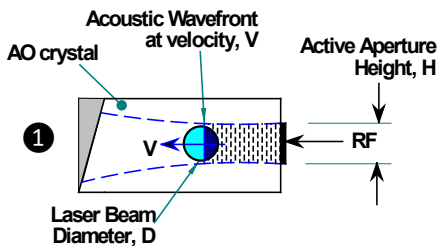
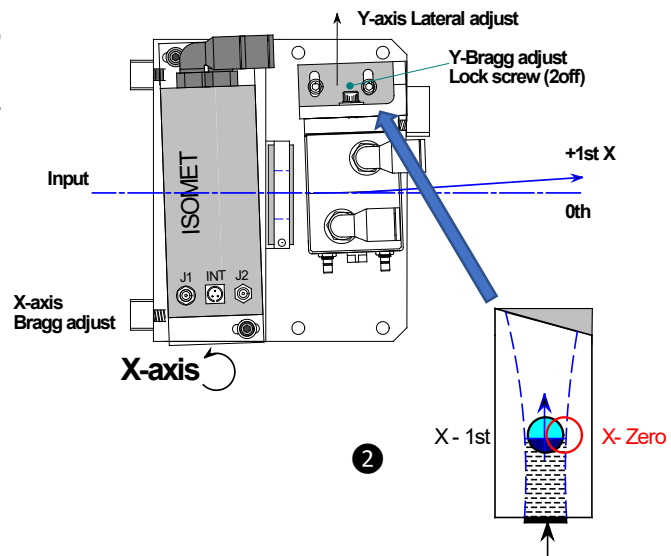

2. Configuration for -1, -1 XY scan

2.1 RF connections

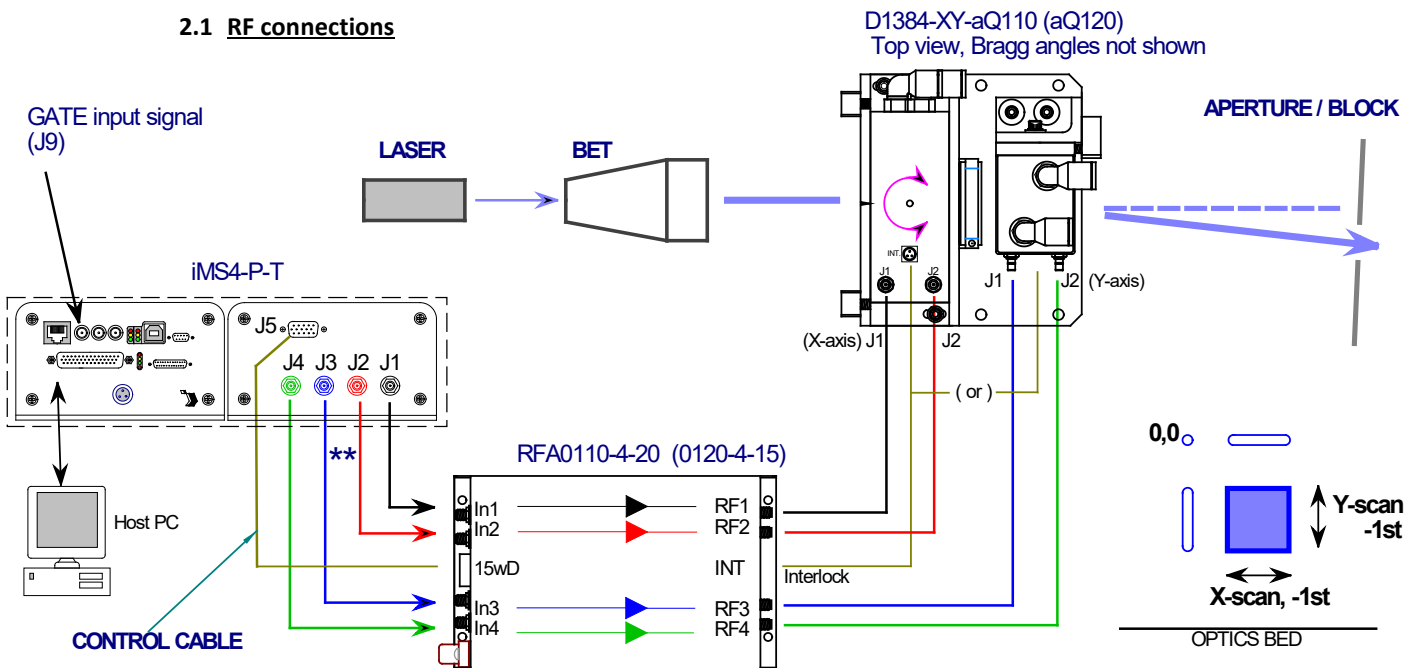

** Note the specific connection order between the four iMS4 outputs to the RFA01x0-4 amplifier inputs.

2.2 Beam Alignment

Angles and lateral adjustments exaggerated for clarity

As drawn here, the correct Bragg angle requires a clockwise rotation of the AO deflector from normal incidence of the input beam.

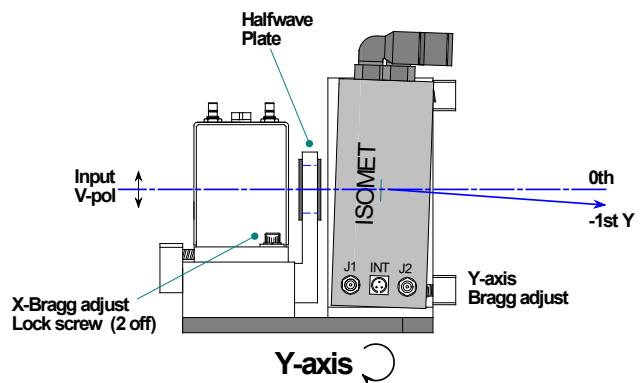

1 Align beam central in aperture, above Bragg Pivot point.

2 For the Y-axis, use slotted holes on the AOD mounts for lateral movement. Align X-axis 1st order output in centre of Y-axis active aperture.

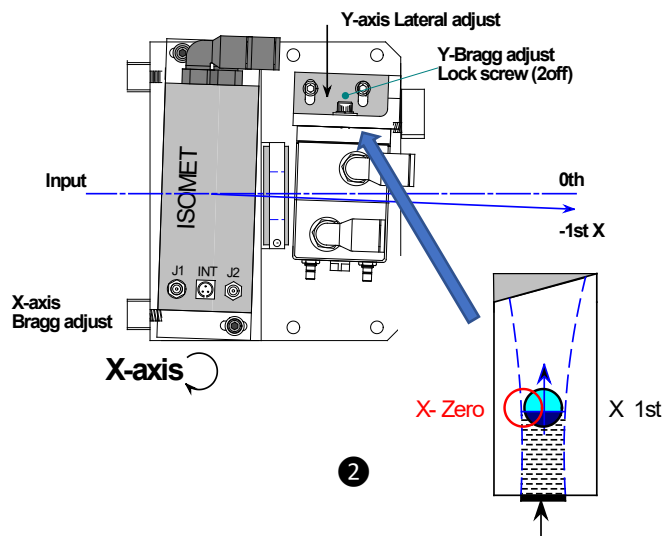
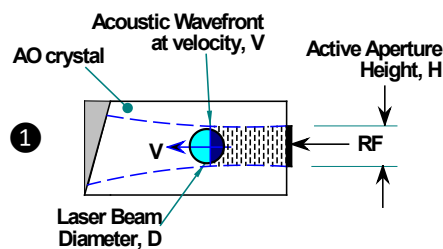

3. Setting X & Y AOD Bragg Angles

The procedure is the same regardless of Bragg orientation.

3.1 Select **Signal Path** tab

iMS4 Rev-C has independent power control for each channel. Ensure all channels are active **Int** (green)

Always ensure values driving each AOD axis are identical

i.e. Ch1 = Ch2 (X-axis)
and
Ch3 = Ch4 (Y-axis)

Tip: Easier to enter number into window(s) than use sliders

Recommended levels are provided on the AOD test data sheet.

e.g. for D1384(XY)-aQ-120-9 at 355nm

DDS= 90%
Ch1 = Ch2 = 50%
Ch3 = Ch4 = 50%

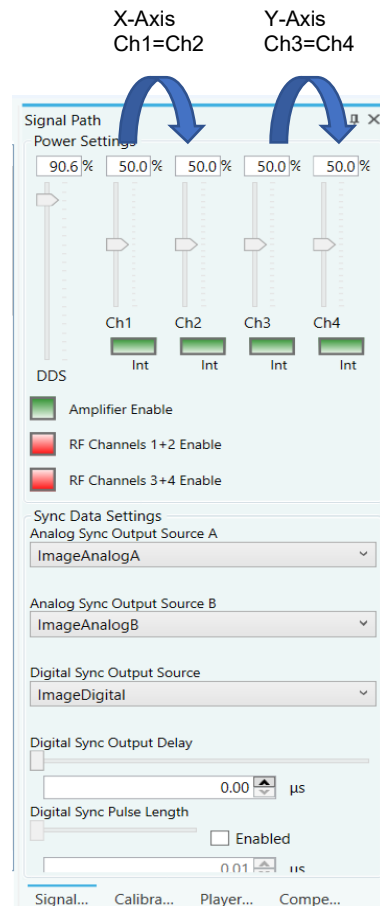

3.2 Select **Calibration** tab

This provides single tone control comprising Frequency Amplitude and Phase (FAP) across all four iMS4 outputs.

4. Bragg Adjust X-axis

Set-up: Drive X-axis only. Y-axis OFF

Method:

To disable Y-axis, reduce calibration Amplitude slider to 0% , then hit the **HOLD** buttons on Ch3 and Ch4 (=red). Ch3 and Ch4 FAP values are now fixed at zero amplitude.

Moving **Amplitude** slider will now adjust power on Ch1 and Ch2 only

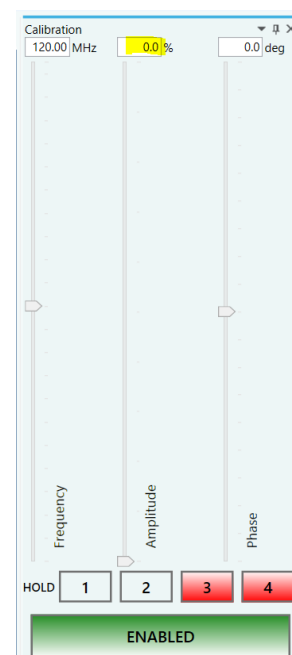

4.1 Place a detector at the X-axis first order beam mid-scan position.
(Not the centre of the XY field)

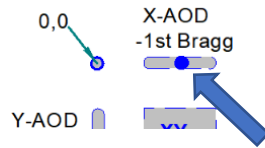

The goal is to achieve the highest uniform efficiency at the lowest average RF drive power. Excessive RF power will reduce efficiency

Set **Calibration** panel sliders for the Bragg Adjustment

1: Set **Frequency** slider to fc.

(e.g. for the D1384-XY, fc = 110MHz for 515nm or 120MHz for 355nm).

2: Set **Phase** to Zero. The Phase is always Zero deg at the Bragg angle.

3: Set **Amplitude** to a starting value of 50%.

Tip: Drag the wiper position using a mouse or enter the value directly in the window and click on the wiper button to activate.

4: Release the two X-axis Bragg adjust lock screws.

5: CAREFULLY adjust the X-axis Bragg angle using the fine thread adjuster to find the peak efficiency. This is sensitive.

An indicator is provided to assists



6: Re-adjust the **Amplitude** slider, down and up, to maximize efficiency (DE). The peak diffraction efficiency should be approx. 80-85% and achieved with **Amplitude** setting of 70-80%

7: Record the peak DE and Amplitude setting.

8: Retighten the Bragg angle lock screws.

Tip: DO NOT overdrive and exceed Psat @ 100%. Better to operate at < 95% and NOT > 100%. As noted from the curve, a small sacrifice in diffraction efficiency of ~2%. will reduce the RF drive power by 10%. This will help to minimize thermal dissipation.

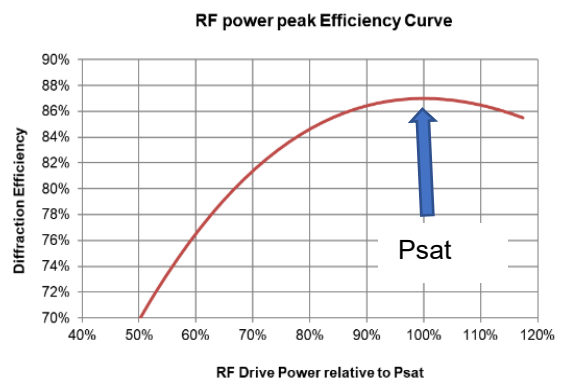
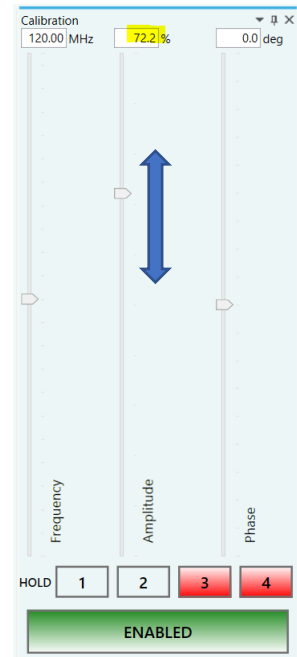

5. Bragg Adjust Y-axis

Set-up: **Amplitude** slider controls Y-axis only

The X-axis amplitude (Ch1, Ch2) is set to a constant power determined in the steps above for X-axis Bragg optimization

Method:

FIRST set the Amplitude slider to values determined previously in Section 4 (e.g. 73.3%) THEN hit the **HOLD** buttons on Ch1 and Ch2 (=red)
Ch1 and Ch2 FAP values are now fixed at 73% amplitude

Moving **Amplitude** slider will now adjust power on Ch3 and Ch4 only

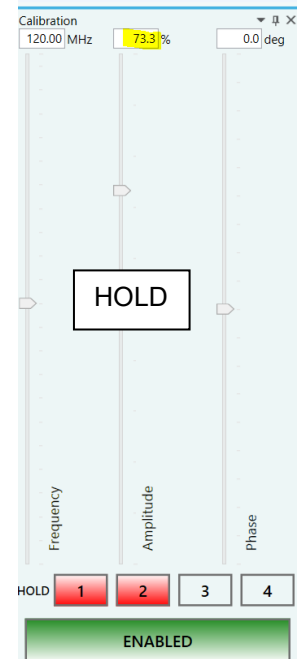

5.1 Place a detector at the centre of the XY field

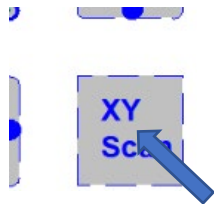

As before, the goal is to achieve the highest uniform efficiency at the lowest average RF drive power.

Adjust Calibration panel sliders for the Bragg Adjustment

- 1: Set **Frequency** slider to f_c .
- 2: Set **Phase** to Zero. The Phase is always Zero at the Bragg angle.
- 3: Set **Amplitude** to a starting value of 50%.

Tip: Drag the wiper position using a mouse or enter the value directly in the window and click on the wiper button to activate.

- 4: Release the two Y-axis Bragg adjust lock screws.
- 5: CAREFULLY adjust the Y-axis Bragg angle using fine thread adjuster to find the peak efficiency.
- 6: Re-adjust the **Amplitude** slider, down and up, to maximize efficiency (DE). The peak overall efficiency is typically found in the range of 70-75% and achieved with **Amplitude** setting of 70-80% .

DO NOT be overdrive. If the efficiency is low, first check the halfwave plate fitted between the X and Y axis (see Sections 6 and 7)

.....when all is optimized.....

- 7: Record the peak DE, Amplitude setting.
- 8: Retighten the Bragg angle lock screws.

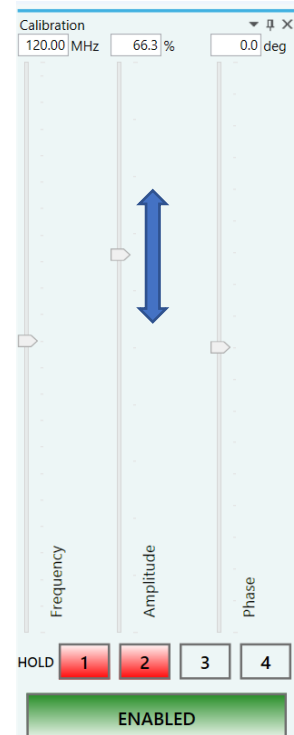

6. Adjust Half Wave Plate

Depending on the AOD model, a half-wave plate is fitted between the X and Y axis. It will be necessary to check the rotation and align the polarization for the orthogonal Y-axis

Place a detector at XY first order mid-scan field position

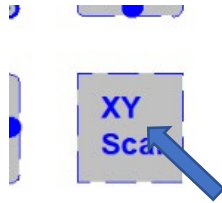

Enable all Channel to drive both the X and Y-axis.

- 1: Set **Frequency** slider to f_c .
- 2: Set **Phase** to Zero. The Phase is always Zero at the Bragg angle.
- 3: Set **Amplitude** to the X-axis Bragg adjust value (= 73% in this example)

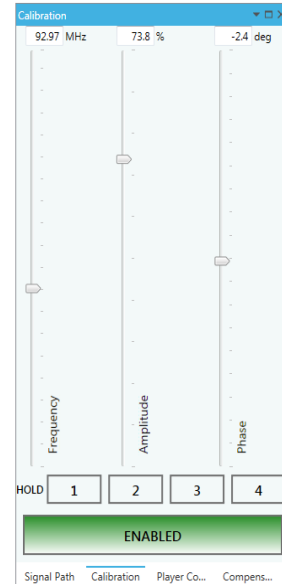

To check orientation of the 1/2 wave plate:

- 4: Loosen the lock or clamp screw
- 5: Carefully rotate the 1/2 waveplate ring for maximum efficiency.
- 6: Re-check Bragg alignment of the Y-axis by carefully making minor adjustments.

7. Result

The overall 2D efficiency at the Bragg angle is the product of the X-axis and Y-axis measured values.
e.g. 85% x 87% = 74%

Expanded view showing 2D scan and required beam block.

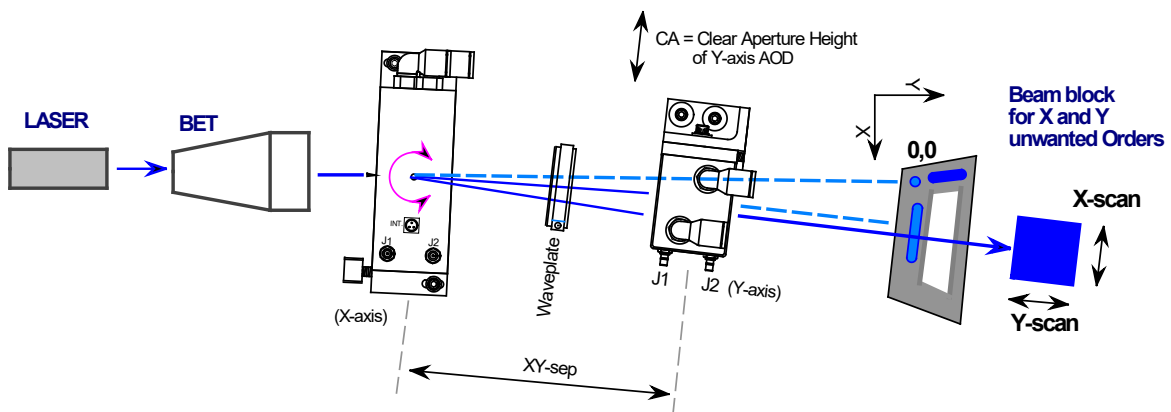

Typical Output Beams, Bragg Angle Adjustment, Single Axis

Adjusting Bragg angle for **-1st** Order Beam

A: AOD normal to input laser Beam

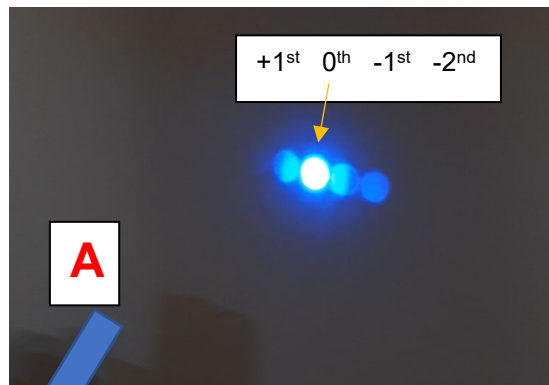

B: Incorrect adjustment

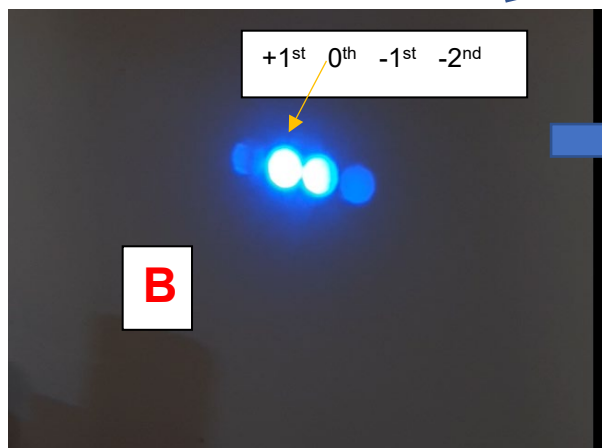

C: Optimized adjustment

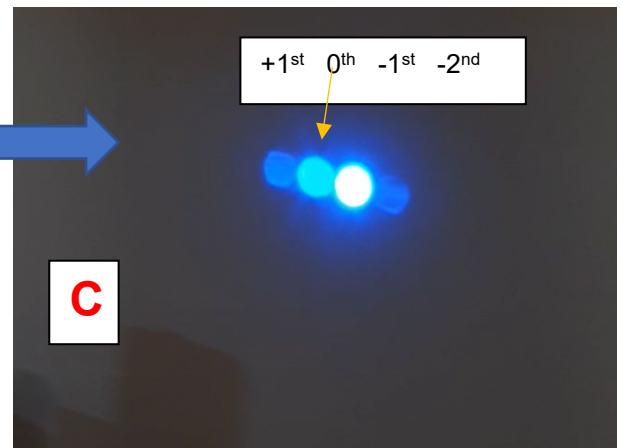

Angle Adjustment is extremely SENSITIVE.

e.g., for the D1384-aQ120- at 355nm

From A -> C = 3.7mrad = 0.15 degrees!

Similarly

Adjusting Bragg angle for +1st Order Beam

A: AOD normal to input laser Beam

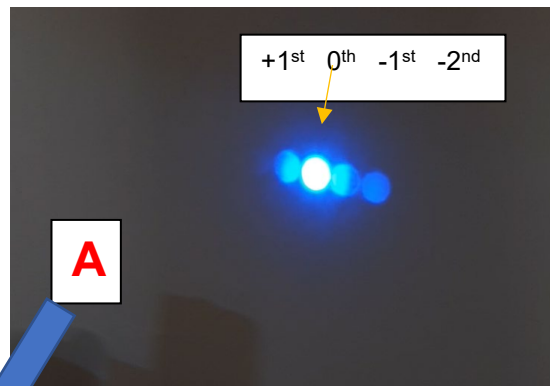

B: Incorrect adjustment

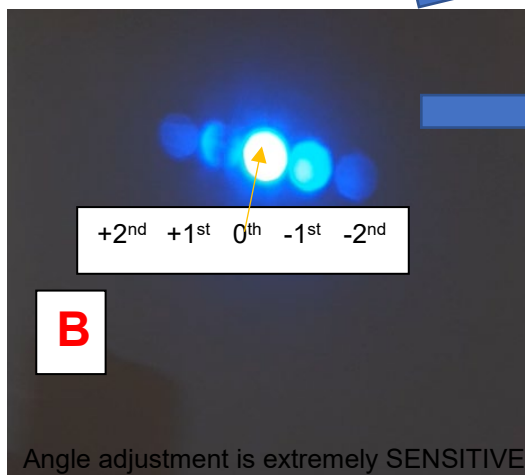

C: Optimized adjustment

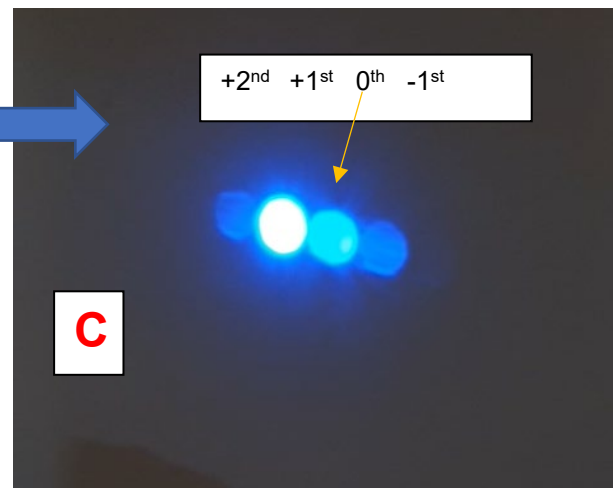

e.g., for the D1384-aQ120- at 355nm
From A -> C = 3.7mrad = 0.15 degrees!

D1384-XY Adjusters Locations

Bragg Adjust = 5/64th Hex Allen key
Lock screws (x2 per axis) = 7/64th Hex Allen key

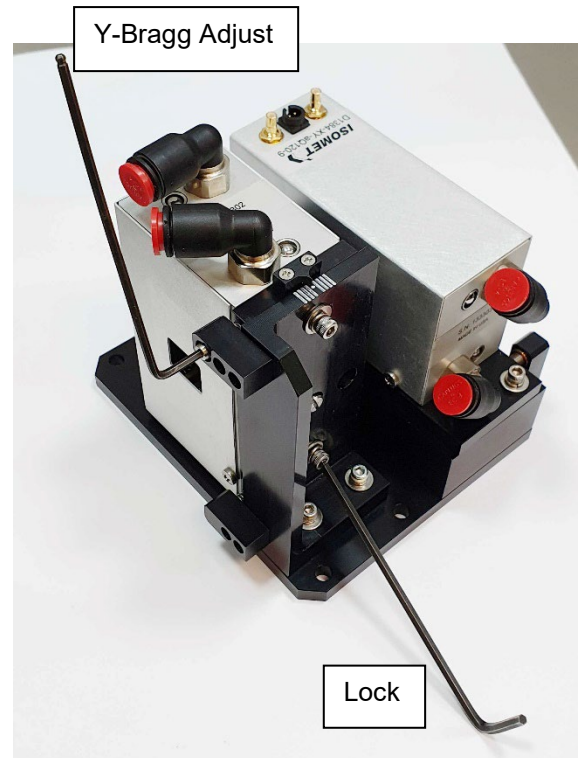
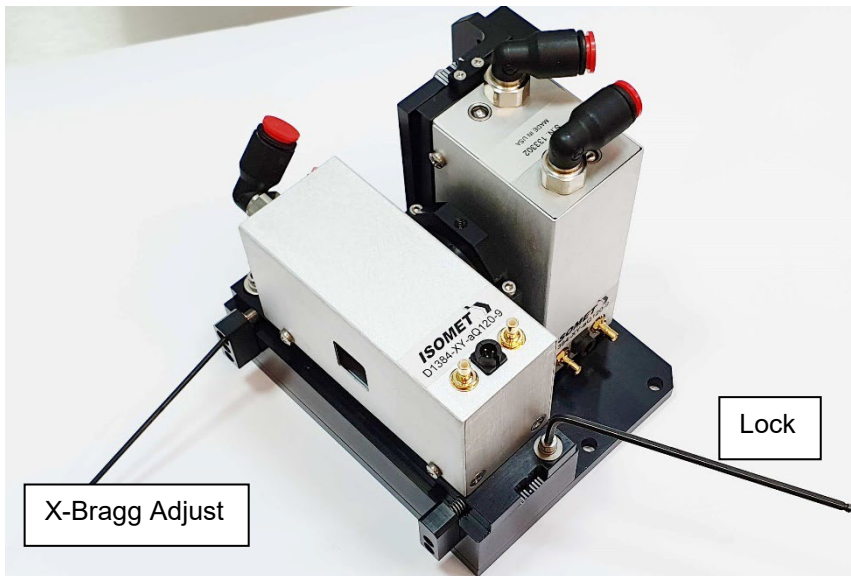

The coolant and RF connections can resist Bragg angle adjustment. It may be necessary to assist the AOD rotation with a little hand pressure on the AOD case. This is most likely needed for counter-clockwise rotation of the Bragg adjuster.

Waveplate adjustment (AOD's removed for clarity)

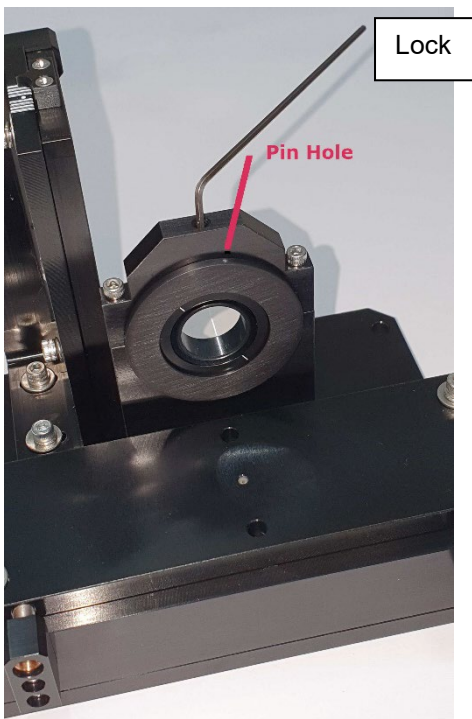

Ring lock screw = 1/16th Hex Allen key

A small pin can be placed in one of 4 holes located around the holder ring. This can help to rotate the half waveplate.